



Use and maintenance instructions EDGE 90°/60° - SYSTEM A/SYSTEM B

Fixed general purpose luminaire, for installation on a concrete plinth
TECHNICAL DETAILS: please refer to the product label

 The UE declaration of conformity can be downloaded from our website www.marecoluce.it

 Insulation Class II

IP65 Protection degree against dust ingress, solid particles, moisture

 This product must not be disposed as a normal household waste

 Caution, risk of electrical shock. The lighting source of this luminaire must be replaced by the Manufacturer only

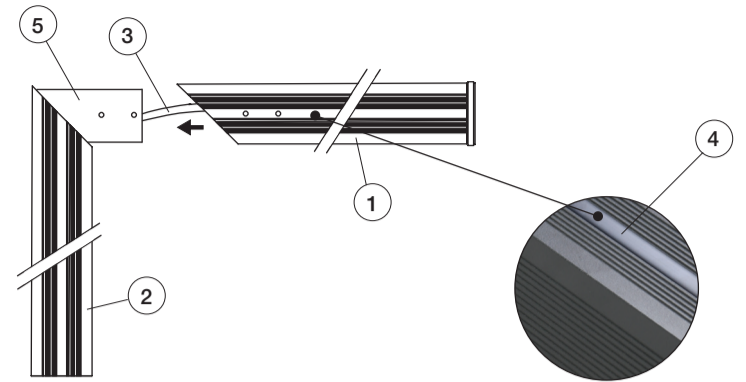

WARNINGS:

- THE SAFETY OF THIS PRODUCT IS GUARANTEED ONLY WITH THE RESPECT OF THE EXISTING RULES FOR THE ELECTRICAL SYSTEMS, AND WITH THE APPROPRIATE USE OF THESE INSTALLATION INSTRUCTIONS, THEREFORE IT IS NECESSARY TO KEEP THEM.
- THE IMPROPER USE OF THIS PRODUCT IS FORBIDDEN; ANY TAMPERING WITH THE PRODUCT OR MODIFICATION OF THE PRODUCT THAT IS NOT AUTHORIZED BY MARECO LUCE CAN CAUSE DAMAGE TO PEOPLE, ANIMALS OR THINGS, AND WILL VOID ANY WARRANTY OR LIABILITY.
- SWITCH OFF THE ELECTRICITY BEFORE CONDUCTING ANY KIND OF MAINTENANCE.
- THE PRODUCT MUST BE INSTALLED IN ACCORDANCE WITH BEST PRACTICE.
- THE LIGHTING SOURCE OF THIS LUMINAIRE MUST BE REPLACED BY THE MANUFACTURER ONLY.
- DAMAGED COMPONENTS MUST BE REPLACED WITH MARECOLUCE ORIGINAL SPARE PARTS.
- DO NOT REMOVE THE PROTECTIVE SHEATH AT THE BASE OF THE POLE AND CHECK IT IS INTACT BEFORE PROCEEDING WITH THE INSTALLATION (SYSTEM A).
- IT IS THE RESPONSIBILITY OF THE INSTALLER TO ENSURE THAT THE MOUNTING SURFACE IS SUITABLE FOR THE SEAL OF THE FLANGE (SYSTEM B).

GENERAL MAINTENANCE RECOMMENDATIONS:

- CLEAN THE LUMINAIRE PERIODICALLY TO REMOVE THE POSSIBLE DIRT DEPOSITS ON IT
- DO NOT USE HARSH DETERGENTS TO CLEAN THE DIFFUSER
- CHECK THE TIGHTENING OF THE SCREWS THAT SECURE THE FLANGE TO THE PLINTH (ONLY SYSTEM B)
- CHECK THE INTEGRITY OF THE FITTING COMPONENTS: REPLACE THEM IN CASE OF DAMAGE BY USING ONLY ORIGINAL MARECO LUCE PARTS

INSTALLATION INSTRUCTIONS SYSTEM A:

1. Prepare the concrete plinth.
2. Insert the illuminating part (1) into the pole (2), paying attention to place the connection cables (3) inside the pole (2).
3. Lift the PC side profile (4) of the illuminating part (1), and connect the illuminating part to the bracket (5) of the pole (2) by tightening the supplied screws (apply 5 Nm).
4. Open the inspection door (6) by using the proper key (included).
5. Insert the power supply cable inside the pole, and connect it to the terminal block following the instructions.
6. Close the inspection door (6) by tightening the screws with the proper key.
7. Place the pole into the plinth.

INSTALLATION INSTRUCTION FOR SYSTEM B USING THE COUNTER FLANGE KIT:

The long side of the flange corresponds to the road side (see Pict. A)

1. Insert the anchor bolts (7) in the respective holes of the counter flange (8).
2. Tighten the nuts (9) 70mm, one nut for each anchor bolt.
3. Prepare the concrete plinth by introducing the kit with anchors and the counter flange and by making sure the counter flange is flush with the plinth.
4. Once the plinth is solid, insert the washers (10).
5. Insert the illuminating part (1) into the pole (2), paying attention to place the connection cables (3) inside the pole (2).
6. Lift the PC side profile (4) of the illuminating part (1), and connect the illuminating part to the bracket (5) of the pole (2) by tightening the supplied screws (apply 5 Nm).
7. Open the inspection door (6) by using the proper key (included).
8. Insert the power supply cable inside the pole, and connect it to the terminal block following the instructions.
9. Close the inspection door (6) by tightening the screws with the proper key.
10. Install the flanged pole (2) and set the nuts (9) to adjust the uniformity of the flange and make sure is flat.
11. Insert the washers (11) and the nuts (12) in the anchor bolts (7) and tighten (apply 10 Nm).

